



ANALYZING THE TECHNICAL CONSTRAINTS OF SINGLE PHASE RESIDENTIAL GRID-CONNECTED PV UNDER NET ENERGY METERING SCHEME

Fahad Raihan Saquib^{1*}, Ankon Chakma and M. S. A. A. F. Shiblee

¹*Department of Electrical Electronic and Communication Engineering, Military Institute of Science and Technology, Dhaka-1216, Bangladesh.*

KUS: ICSTEM4IR-22/0220

Manuscript submitted: August 11, 2022

Accepted: September 25, 2022

Abstract

Integrating clean and sustainable energy sources into the conventional utility grid benefits both the environmental concerns and the economy. The net energy metering (NEM) scheme is convenient in this situation. After meeting the energy requirements of its associated loads, it integrates excess photovoltaic (PV) generation into the main grid, lowering the cost of massive battery storage and increasing the supply of clean energy to the grid. From the perspective of single-phase residential grid-connected PV systems, this can have beneficial repercussions in addition to the aforementioned cause. Integration of a single-phase distributive generation system, such as solar PV with the utility grid, introduces various concerns with power quality issues, including overvoltage, an increase in fault level and harmonics effect. This paper evaluates the effects of technical parameters on residential single-phase grid-connected photovoltaic integration with the IEEE 14 bus system. Matlab/Simulink is used to develop the system, which includes an IEEE 14 bus and a single-phase grid-connected PV module connected to the following bus with its associated residential loads. The effects of varied PV module sizing and load variation on the technical parameters are observed. The research findings are compared to the current models of residential three-phase grid-connected PV under the NEM scheme. The proposed sizing and mitigation of the system's impact by technical concerns are discussed.

Keywords: Net Energy Metering, Grid-connected PV, Power Quality, Single Phase System, Harmonic Distortion, Matlab/Simulink

Introduction

The energy requirements of the modern world are escalating and the fossil-based energy resources are being degraded at a shocking rate. Due to the increased consumption of fossil fuels, climate change has become an alarming problem to resolve. For example, the emission of greenhouse gases during the manufacturing of fossil fuels has sparked significant concerns regarding global warming. Significantly increased use of renewable sources

*Corresponding author: <fahadraihaan004@gmail.com>

DOI: <https://doi.org/10.53808/KUS.2022.ICSTEM4IR.0220-se>

might save a substantial amount of money and significantly aid in the fight against global warming (Rehman et al., 2020) (Ashraf Chaudhry et al., 2007) (Khajeh et al., 2020).

In this instance, net energy metering has the potential to be beneficial because of the contribution of clean energy to the grid while also enhancing economic benefits. Solar energy that is grid-connected does not require storage under a net metering scheme, which results in cost savings.

NEM facilitates the trade of excess electricity generated from renewable sources to the distribution grid following self-consumption. In exchange, the prosumer (a consumer who also generates power) may import an equal amount of grid electricity or receive the price of the net amount of electricity exported at the completion of the settlement period (Chowdhury & Khan, 2020).

In grid-connected PV systems operating under the NEM scheme, the DC electricity generated by PV panels is converted to AC power via an inverter and then delivered directly into the grid. The inverter performs the matching of frequency and voltage (Miah et al., 2020).

This system may experience voltage variations, power variances, distorted power factor, and harmonic distortions, among other power quality difficulties (Gupta et al., 2018).

In terms of supplying power flow in a single path, distribution systems are radial in form. Integration of DG (distributed generation technologies) in the infrastructure improves power reliability of supply, lowers grid degradation and load consumption. However, designs like as net metering that allow reversal power flow due to the greater penetration and intermittent nature of DG may alter the regulatory and technological aspects of the grid. Providing active energy to a home network results in different protection system failures and instability, voltage increase, cable overload, and increased fault current. (Celvakumaran et al., 2018).

Regarding the technical aspects of this scenario, multiple researches have been conducted so far. Typically, the majority of work is executed using PV with a three-phase system.

In Chowdhury and Khan (2020), a model and performance evaluation of Photovoltaic connected in three-phase to the integrated IEEE 14 bus network in the MATLAB/SIMULINK software are shown. The performance of the designed power distribution network is evaluated for different irradiance, load magnitude, and load type circumstances. Simulations are conducted in terms of voltage/power variations and Harmonic Content Distortion at Point of Common Coupling in order to assess the effect of PV integration on key power quality metrics.

A research work has been done in Celvakumaran et al. (2018) about analyzing the technical challenges caused by net energy metered scheme from the perspective of the Malaysian distribution system. The research demonstrates that high capacity net metering might generate power quality difficulties in the system, like an increase in voltage, fault level intensification, and harmonic distortion. This study analyzes the acuteness of power characteristics challenges as solar PV penetration increases. The entire operation relied on PV with a three-phase connection.

A proposed design and execution method in Arshad and Ahmad (2021) for a three-phase, on-grid solar PV system on a rooftop is presented. Results are primarily focused on practicability and economic viability. A conducted work in Murdan and Jeetun (2021) presented is the design and installation of a single-phase grid-connected PV system. Its depiction is based on a customer engaging in a net metering program so that its performance may be compared to that of a typical client. The advantages of the net metering method are highlighted, along with the practicality of feeding excess production to another customer on the same phase.

In Saquib et al. (2021) the cost-efficacy of Net Energy Metering of a single-phase Residential Grid-tied PV is presented. Discussion on the future implementation of a single-phase residential grid-connected PV from the perspective of Bangladesh and also the economic viability of the implemented design is presented.

In the aforementioned research works, technical difficulties pertaining to three-phase grid-connected PV under NEM or the economic viability of single-phase residential grid-connected PV were studied. Analyzing the technical aspects of single-phase PV with grid-connectivity systems is important. This study presents an analysis and discussion of single-phase residential PV systems connected to the grid under NEM.

The rest of the paper is organized following Materials and Methods, Results, Discussion, and Conclusion.

Materials and Methods

IEEE 14 bus model is used in the simulation done with Matlab/Simulink. PV arrays are connected with a residential single-phase residential load in the solar bus which is tied with the IEEE14 bus model shown in Figure 1.

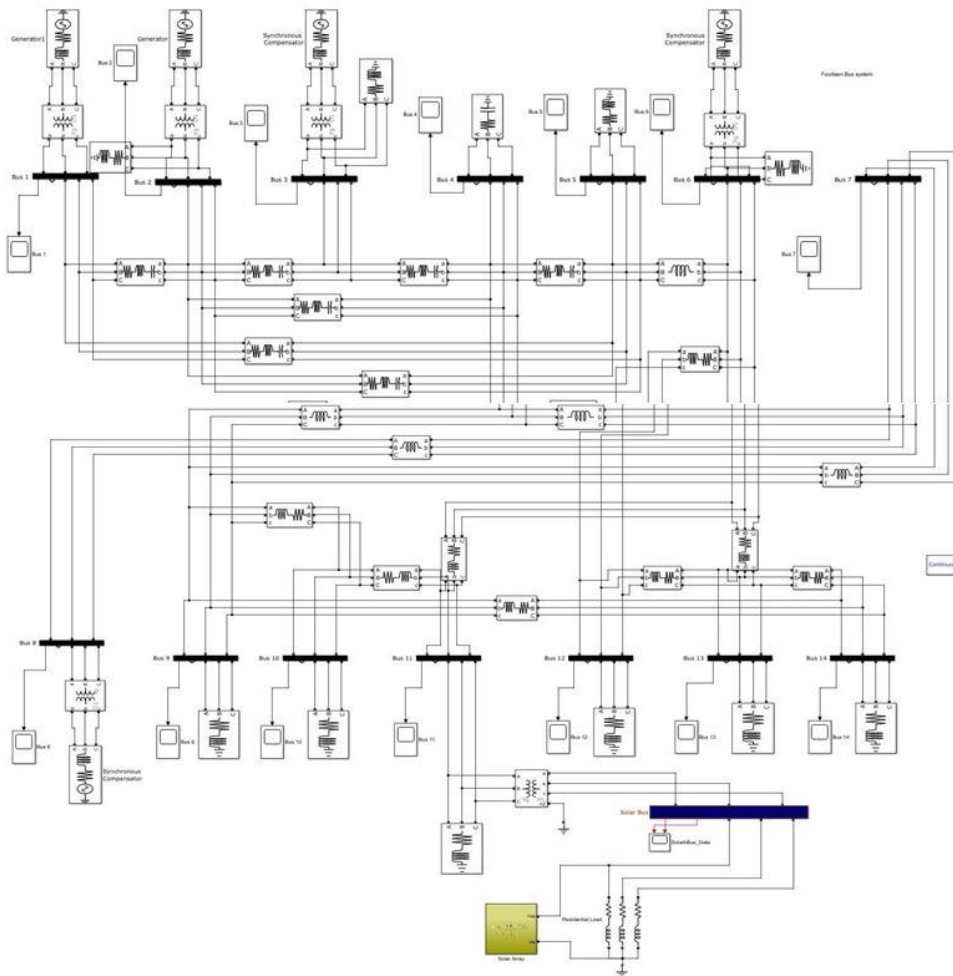

Figure 1. IEEE 14 bus model connected with single-phase grid-tied PV.

This model consists of 14 buses, 5 generators, 11 loads (Gupta et al., 2018) connected with the solar bus which has three-phase residential loads in which one phase is connected with a grid-tied PV. The maximum number of PV arrays connected is 40. The open-circuit voltage of each module is 36.3 V and the voltage at the maximum power point is 27 V. The total generation of all the models is around 7.5kW where each module produces around 198 W at 1000 W/m² irradiance and 25^o centigrade. The percentage of the PV is calculated based on the active panels to the total no of installed capacity panels (Celvakumaran et al., 2018).

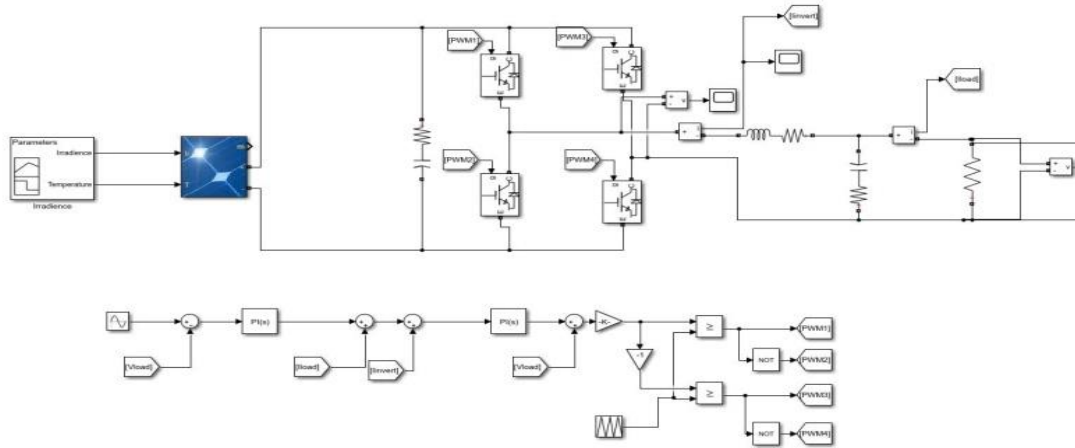

Figure 2. PV array connected to single-phase ac grid via an inverter.

An inverter is used to connect the PV with the single phase of the ac grid in Figure 2. The single-phase residential load where the PV is connected varies between 5kW to 15kW. The overall model is simulated and results are observed based on the unbalanced phase voltage, harmonics effects and load variations.

Results

Simulation of the system, which includes an IEEE 14 bus and a single-phase grid-connected PV module connected to the following solar bus with its corresponding residential load, is performed with the help of Matlab/Simulink for 10 seconds to validate the feasibility of the proposed strategy. The impacts of the different PV module sizes and the fluctuations in load on the power quality concerns are seen. These power quality issues include phase unbalanced voltage, harmonics effects, and over-voltage. The study outcomes are then compared to current models of residential three-phase grid-connected PV under the net metering system.

Effect on phase unbalance by varying PV Module Sizes

Figure 3. indicates the voltage of all phases when the IEEE bus system is isolated with PV panels valued at 134.9V. In this particular instance, there are 5 PV panels that are linked to the IEEE 14 bus system. According to Figures 4. and 5., the voltage at the corresponding PV connected phase peak voltage is shown to be 132.3V, whereas the voltage at all other phases is shown to be 135V. This voltage difference is discovered because the system is only linked to a single-phase, while the other phases are not directly linked to the PV system. As seen in Figures 6 and 7, the voltage on the associated PV connected phase is 399.2V, but the voltage on the other phases is 404.9V.

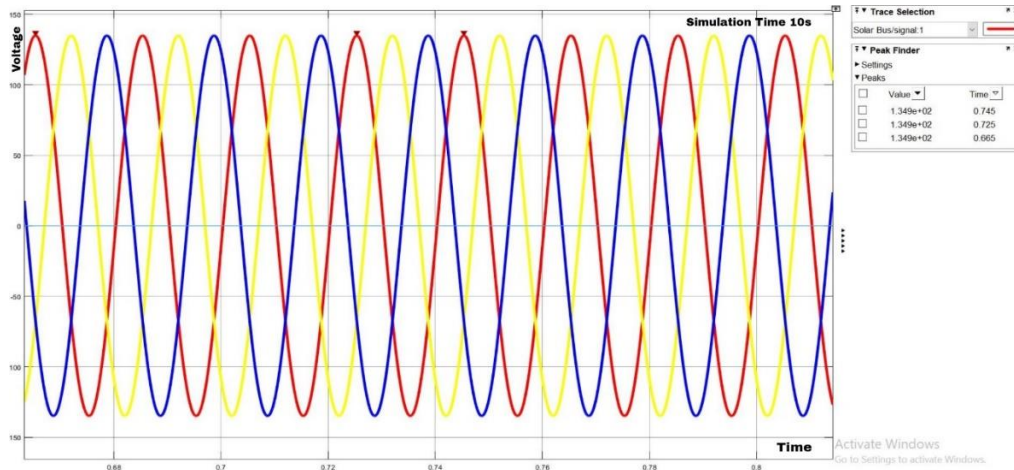

Figure 3. Voltage at all phases when connected with no PV panels.

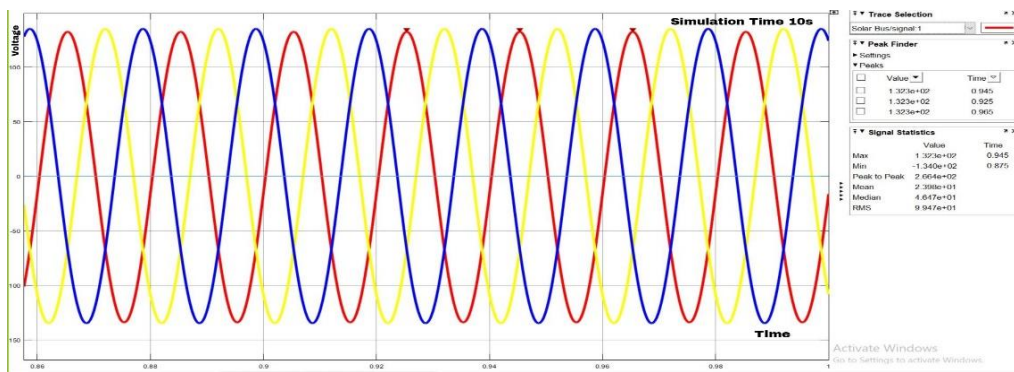

Figure 4. Voltage at PV connected single phase when connected with 5 PV panels.

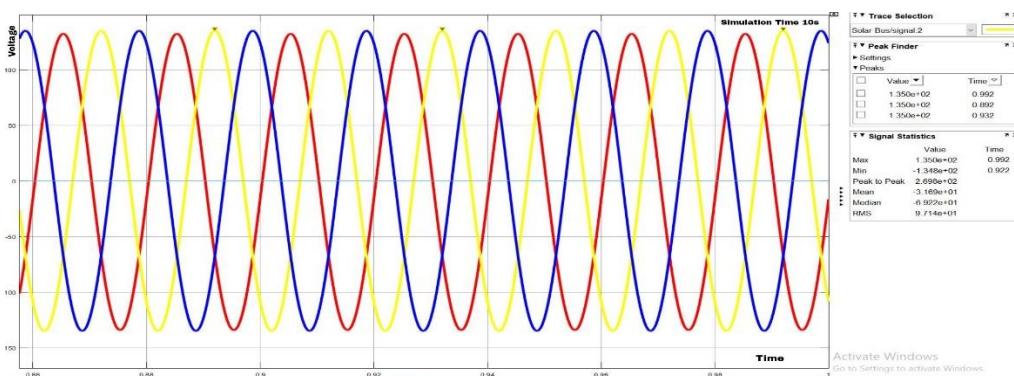

Figure 5. Voltage at other phases when connected with 5 PV panels.

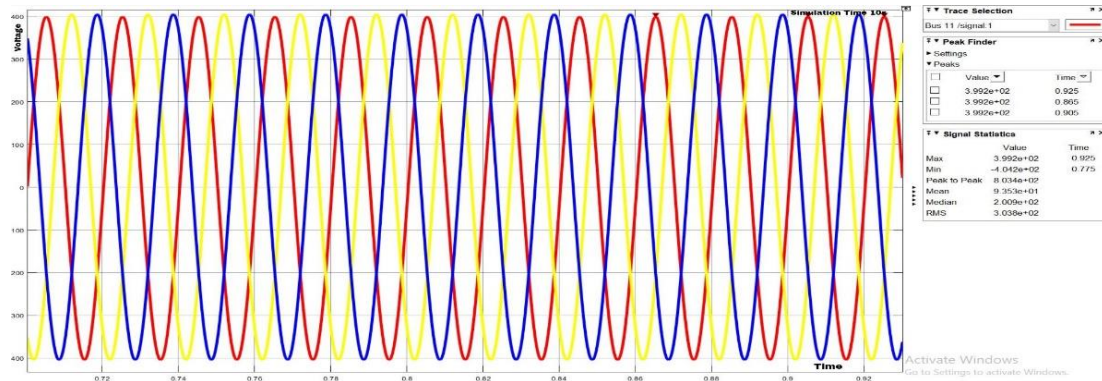

Figure 6. Voltage at single phase of nearby bus when connected with 5PV panels.

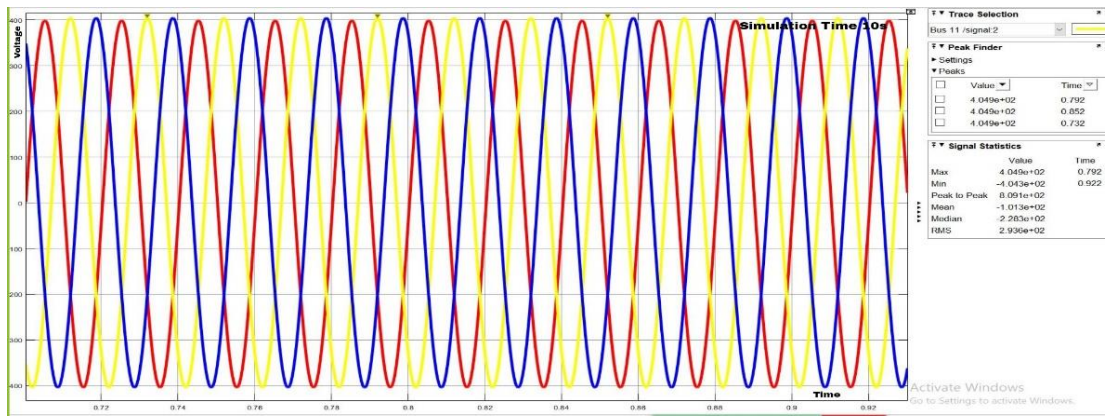

Figure 7. Voltage at nearby bus when connected with 5PV panels.

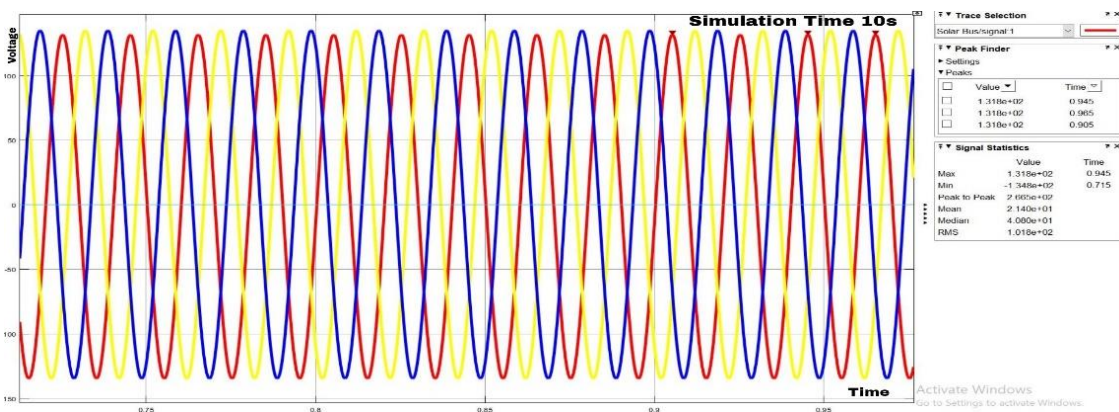

Figure 8. Voltage at PV connected single phase when connected with 15 PV panels.

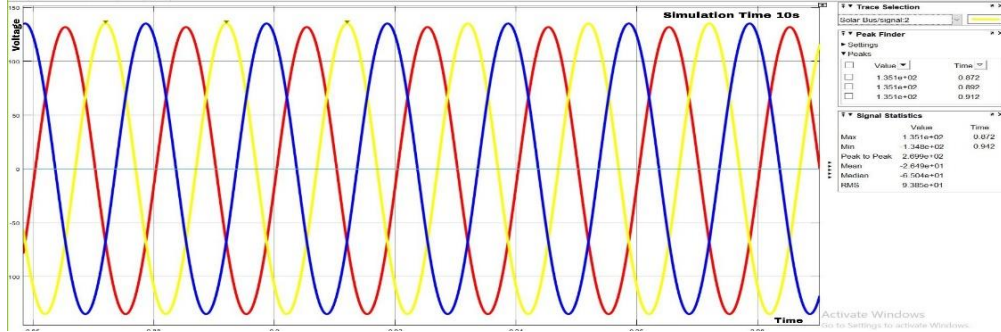

Figure 9. Voltage at other phases when connected with 15 PV panels.

In this case, there are 15 PV panels that are connected to the bus system. Figure 8. indicates a peak voltage of 131.8V for the corresponding single-phase and for the other phases the value is 135.1V in Figure 9. The voltage on the corresponding near bus single phase is 397.6V, whereas the voltage on the other phases is 405.1V.

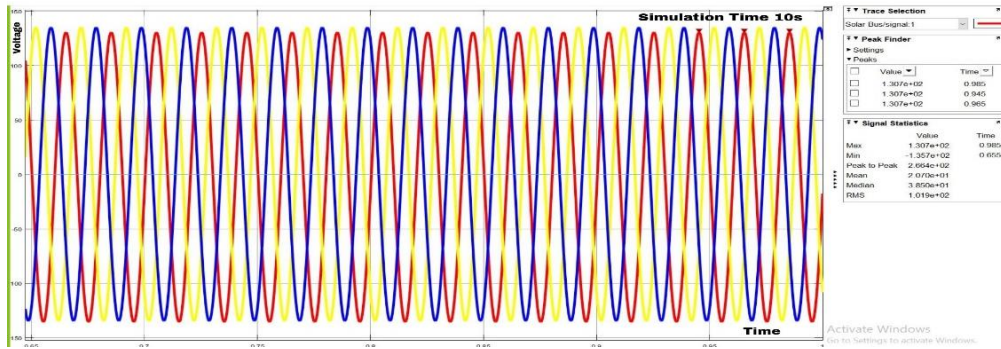

Figure 10. Voltage at PV connected single phase when connected with 30 PV panels.

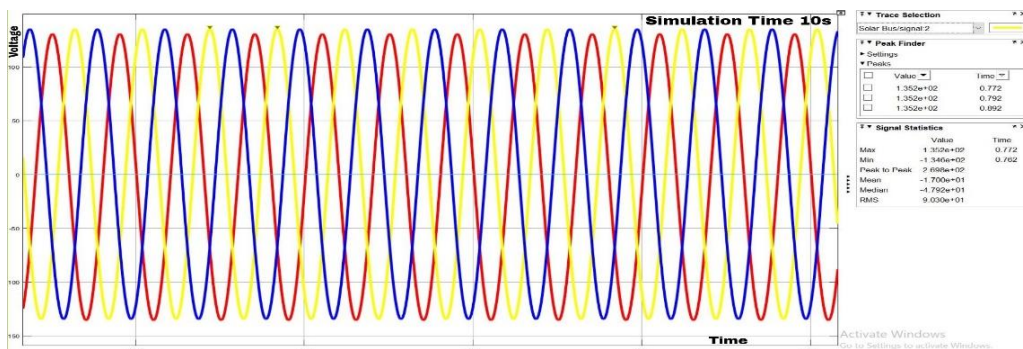

Figure 11. Voltage at other phases when connected with 30 PV panels.

In this scenario, the system is connected with 30 PV panels. Figures 10 and 11 show that the voltage for the single-phase is found to be 130.7V and that the voltage for the other phases is 135.2V. The voltage on the nearby bus's single phase is 394.5V, whereas the voltage on the other phases is 405.4V.

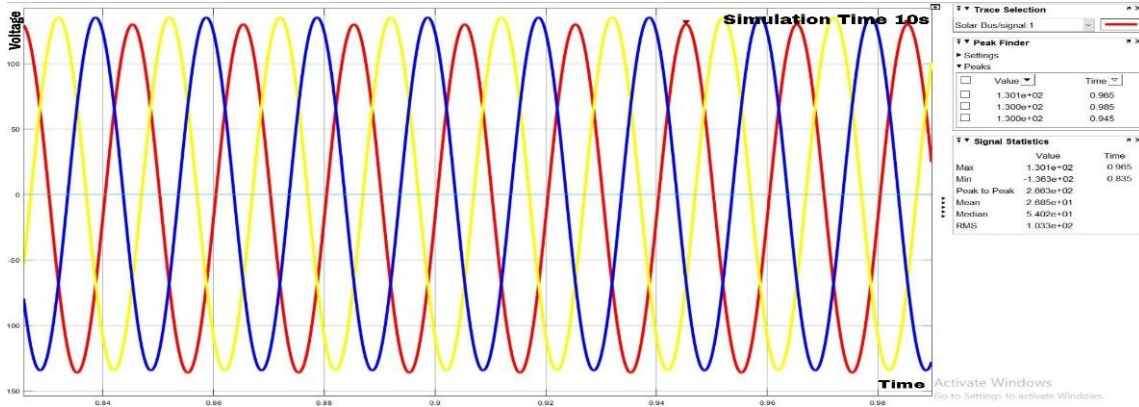

Figure 12. Voltage at PV connected single phase when connected with 40 PV panels.

In this particular case, there are 40 photovoltaic panels that are linked to the IEEE 14 bus system. Figure 12 shows a voltage of 130.1 volts for the single-phase that corresponds to the system and the value of the other phases is 135.3 V. The nearby bus's single-phase voltage is 392.6V, but the voltage on the different phases is 405.6V.

The varying size of the PV panels is seen to have an effect on the voltage of the PV-connected phase, while the voltage of the other phases remains constant. With increasing PV size, the voltage of the corresponding PV-connected phase linked to the bus of IEEE 14 continues to drop. The voltage difference between phases is also seen varying while varying the size of the PV panels shown in Table 1.

Table 1. Voltage difference between phases while varying PV size

Number of PV panels connected with the system	Peak Voltage at PV connected single phase(V)	Peak Voltage at other phases(V)	Voltage difference between phases(V)	Voltage at PV connected phase of nearby bus(V)	Voltage at other phases of nearby bus(V)	Peak Voltage difference between phases(V)
0 (0% PV)	134.9	134.9	0			
5 (12.5%PV)	132.3	135	2.7	399.2	404.9	5.7
15(37.5%PV)	131.8	135.1	3.3	397.6	405.1	7.5
30(75% PV)	130.7	135.2	4.5	394.5	405.4	10.9
40(100% PV)	130.1	135.3	5.2	392.6	405.6	13

Effects on the PV Connected Phase by Varying Residential Load

Table 2. Change in phase voltage while varying load.

Number of PV Module	Peak voltage of single phase(V)		
	When load is 5KW	When load is 9KW	When load is 15KW
5	132.5	132.4	132.3
15	131.8	131.7	131.6

The IEEE 14 bus system’s solar bus is connected with 5 and 15 PV modules in two different cases. In both cases, the voltage of the phase associated with the system tends to change by varying the load. Table 2. shows that a decrease in single-phase voltage occurs with the increase of load.

Harmonics Effect

Table 3. shows that Total Harmonic Distortion (THD) tends to increase with the increase of active solar panels. Here, the THD of our model is compared with another existing model (Celvakumaran et al., 2018).

Table 3. Comparison of Total Harmonic Distortion

Models with Bus Name	THD of Voltage without Solar PV	THD of Voltage at 33%-37.5% Solar PV	THD of Voltage at 60%-75% Solar PV	THD of Voltage at 100% Solar PV
.4KV Bus II	.261	.382	.396	.702
Solar Bus	.04	.05	.09	.09

In this work’s case (PV is connected with the single-phase), THD is low as only one residential load has been considered, while the other model is connected with several PV systems with the residential loads (all the PV connections are three phases). THD will increase with the increase of the percentage of solar PV modules. Figure 13. shows the order of the harmonic at the 100% PV connected to the single-phase connection.

Discussion

Single-phase PV grid connection has both advantages and technical challenges. Integration of a substantial amount of PV in a single phase may result in serious technical challenges due to the unbalanced three-phase system and system instability. If a single-phase is linked to PV, the other phases can be connected to an estimated amount of PV to avoid several technical complications by balancing them. In this instance, power transfer will also be beneficial. The variance in residential load has minimal bearing on this matter. Significant load fluctuations can result in technical challenges. Harmonics are dependent on PV panel size. A high number of installed single-phase PV connected to the grid can create complications. The overall size must be determined with consideration of the accompanying loads. In the simulation, the maximum load demand is 15 kW, although the maximum PV capacity installed was approximately 7.5 kW, resulting in less variance in the technical parameters. Increasing the amount of PV will have some effect on the system. Utilizing several facts devices and sizing PV appropriately can decrease technological complications. PV connected to a single-phase grid can be

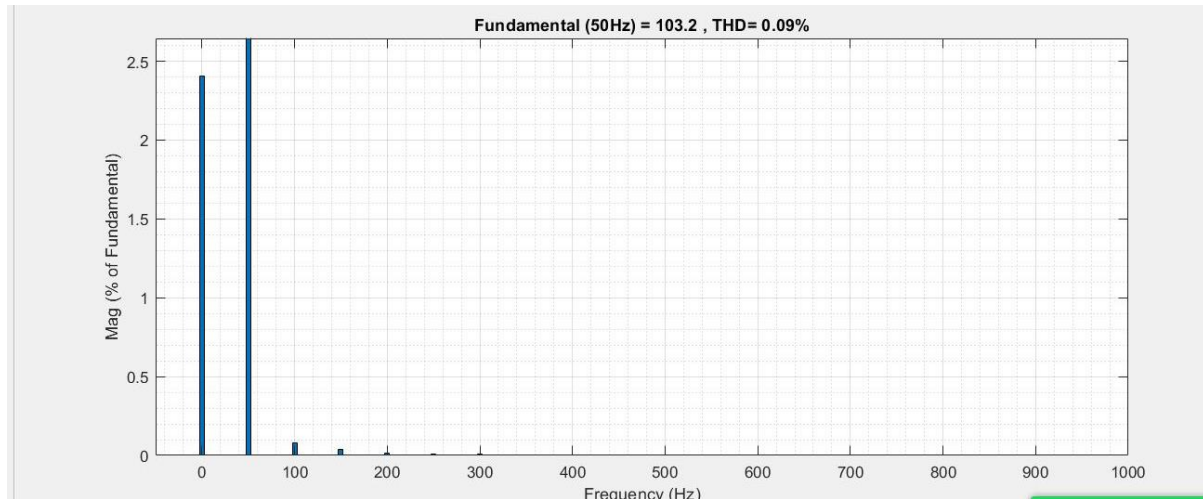

Figure 13. THD at 100% installed PV.

cost-effective due to its lower installation costs and its economic benefits to prosumers as it sends excess energy to the utility grid.

Conclusion

PV panel's connection with the single-phase load in a large three-phase system may have some complications though it has constructive environmental and customer beneficial aspects. For addressing the technical challenges, more study may be done by taking into account the hazardous issues and load forecasting facts in the future regarding this grid tied PV integrated with single phase system. In this study, the amount of PV linked is minimal compared to the overall system' load. Further work should be done for a high number of installed grid coupled single-phase PV connected to the system. This form of distributive generation can bring sustainability to the grid and also beneficial for the environment as it is clean energy. It can also be utilized for small scale ac microgrid for more stability purposes.

References

- Arshad, H. M., & Ahmad, M. (2021). Design and Performance Analysis of a Net Metering Rooftop Solar PV System. 2021 2nd International Conference for Emerging Technology (INCET). <https://doi.org/10.1109/incet51464.2021.9456397>
- Ashraf Chaudhry, M., Raza, R., & Hayat, S. (2007). WITHDRAWN: Renewable energy technologies in Pakistan: Prospects and Challenges. *Renewable and Sustainable Energy Reviews*. <https://doi.org/10.1016/j.rser.2007.04.006>
- Celvakumaran, P., Ramachandaramurthy, V. K., Padmanaban, S., Padmanathan, K., Pouryekta, A., & Pasupuleti, J. (2018). Technical Constraints of Integrating Net Energy Metering from the Malaysian Perspective. 2018 IEEE PES Asia-Pacific Power and Energy Engineering Conference (APPEEC). <https://doi.org/10.1109/appeec.2018.8566496>
- Chowdhury, S. A., & Khan, M. Z. R. (2020). The Net Metering Guideline of Bangladesh-Potential and Way Forward. 2020 11th International Conference on Electrical and Computer Engineering (ICECE). <https://doi.org/10.1109/icece51571.2020.9393148>

- Gupta, S., Garg, S., Babbar, V., Saha, S., & Nagarwal, N. (2018). Modeling & Performance Investigation of PV Integrated IEEE 14 Bus Test System. 2018 International Conference on Computing, Power and Communication Technologies (GUCON). <https://doi.org/10.1109/gucon.2018.8674923>
- Khajeh, K. G., Solatiolkaran, D., Zare, F., & Mithulananthan, N. (2020). Harmonic Analysis of Multi-Parallel Grid- Connected Inverters in Distribution Networks: Emission and Immunity Issues in the Frequency Range of 0–150 kHz. *IEEE Access*, 8, 56379–56402. <https://doi.org/10.1109/access.2020.2982190>
- Miah, M. A. R., Rahman, S. R., & Kabir, R. (2020). Techno-Economic Assessment of Net Energy Metering Implementation for Rooftop Solar PV in a Commercial Building in Bangladesh. 2020 4th International Conference on Green Energy and Applications (ICGEA). <https://doi.org/10.1109/icgea49367.2020.239712>
- Murdan, A. P., & Jeetun, A. K. (2021). Simulation of a Single Phase Grid-tied PV System under Net-Metering Scheme. 2021 IEEE Power and Energy Conference at Illinois (PECI). <https://doi.org/10.1109/peci51586.2021.9435288>
- Rehman, W. U., Bhatti, A. R., Awan, A. B., Sajjad, I. A., Khan, A. A., Bo, R., Haroon, S. S., Amin, S., Tlili, I., & Oboreh-Snapps, O. (2020). The Penetration of Renewable and Sustainable Energy in Asia: A State-of-the-Art Review on Net-Metering. *IEEE Access*, 8, 170364–170388. <https://doi.org/10.1109/access.2020.3022738>
- Saquib, F. R., Chakma, A., Rahman, A. Y., Sneha, F. H., Shiblee, M. S. A. A. F., & Riad, M. R. (2021). A Case Study on the Cost-effectiveness of Net Energy Metering of Residential Grid-Connected Photovoltaic in the Context of Bangladesh. 2021 5th International Conference on Electrical Engineering and Information Communication Technology (ICEEICT). <https://doi.org/10.1109/iceeict53905.2021.9667846>