



## REPRESENTATION OF FORMAL AND SPATIAL ANALYSIS IN COMPUTATIONAL MEDIA: A CASE STUDY OF NATIONAL ASSEMBLY BUILDING IN DHAKA

Hafizur Rahaman\* and Sk. Maruf Hossain

*Architecture Discipline, Khulna University, Khulna 9208, Bangladesh*

**Abstract:** In architecture, the primary goal of a design analysis and its representation is to expose the underlying concept, organizational pattern, design characteristics, and ‘tectonics’ through simplified diagrams. Last few years there shows a distinct elevation of general mass education in graphics and audio-visual media. In contrast, the average level of understanding architectural representation is still much lower than most other visual media. The advent of computers recently has added 3D models and 3D motion models (animations) into the spectrum of representation. This study investigates the strength and limitations of conventional computer aided 3D diagrammatic modelling techniques and their related representative capabilities in the context of architectural form and space analysis. Here, National Assembly Building, Dhaka is used as a case study. The authors hope, the findings of this study will help to understand the new media and it’s significant importance in the context of architectural analysis and design teaching.

**Key words:** Architecture, form analysis, representation, 3D model, analytic diagram.

### Introduction

Throughout history, the notion of ‘precedent’ has always provided conceptual models to serve the quest for appropriate architectural forms. It is a relatively recent phenomenon that considers architecture through a veil of literary metaphors. Since the end product of architecture is a built outcome, the most basic theoretical stance must be supported in turn by a few fundamental grammars. That grammar must need to be expressed physically, which could demonstrate the adaptation of a theory into successful acceptable architectural solutions with a certain degree of clarity (Uddin, 2001).

Moreover, analysis of form and space is an essential part of general practice in architecture. Architecture is such a field where learning always provides feedback to each and every project. In order to do so, professionals used different types of complex drawings which are often very hard to generate. But the new generation of computer with its complex analytical data handling capability offers new degree of hybrid drawings to ensure new avenue of representation techniques for analysis of architectural form and space. The computer medium has an edge in representation of analysis because of its ability to create motion models with variations of parametric changes (event based animation). Computer 3D models converted into Real Time Navigation offers interaction to a viewer to view the model from any angle and to understand spatial composition of its components.

\* Corresponding author. Tel: +88041-721791,720171-3(222); Fax:88041-731244 . <hrahaman@gmail.com>  
DOI: <https://doi.org/10.53808/KUS.SI.FRCC.2006.27-33-se>

The objective of the study is to investigate the strength and limitations of basic 3D diagrammatic models and their capabilities in the context of graphic analysis of architectural form and space. The focus of such analysis is to create 3D-computer models by using different popular modeling techniques to represent visual analysis of architectural form and space. The study also highlights the restrictions that were found in each technique.

## Materials and Methods

Traditionally, plans, elevations, sections, axonometric, perspectives, physical models, and photographs are our means of representing form, space, and its analysis. These conventions of drawings date back to the Fifteenth Century. Although computer 3D environment has successfully converted these conventions, we have not seen any new drawing types with the advent of new digital media (Uddin, 2001). Constructing and composing objects in a three-dimensional computer environment that have length, width and depth are usually referred to as 3D modeling. These computer generated geometric model/3D model can be stored in a computer in two different ways:

- i. Without primitives in the so called pixel – or painting programs
- ii. With primitives in drafting and design packages; both differing significantly in structure and capabilities

A computer generated model set up with primitives, knows the entities it is handling. This model consists of structured, labeled and identifiable entities like *vertices*, *edges*, *surfaces* and *solids* from which information is stored in a data structure. Only when this kind of structure exists, we can perform all kind of intelligent manipulation, like editing (delete, rotate, move, scale.....), defining coherence, etc. With primitives three types of modeling can be done: (i) Polygonal modeling, (ii) Patch modeling and (iii) Nurbs modeling. All of these models have their own techniques of data handling, manipulating and editing capabilities.

It is evident that same modeling package (e.g. Maya, Max etc.) do not work equally well in all types of model buildings and that's why there is an ongoing competition to devise new packages. In order to find out how far the above three modeling techniques work on building with complex forms and planes, we choose the National Assembly Building, Dhaka. Then we conducted the study in the following three steps:

**(a) Literature survey:** A literature survey was conducted to collect the recent information for making 3D Virtual Modeling of the building.

**(b) Physical survey:** Detail physical survey including measurement of prime dimensions of the building was conducted for this purpose.

**(c) Analysis of the information and computer modeling:** Collected information were then processed and electronically entered into the computer for making 3D models. Computer programs (like: AutoCAD, 3D Studio Max and Photoshop etc.) were used to create 3D models with variations of parametric changes. By using computer as a tool different models and hybrid images of the National Assembly Building were then extensively analyzed for understanding the extent and limitation of the representation capability of computer media.

## Results

The outcome of the experiments gave a number of 3D models prepared by different techniques. Fig. 01 was prepared by Polygonal modeling techniques.

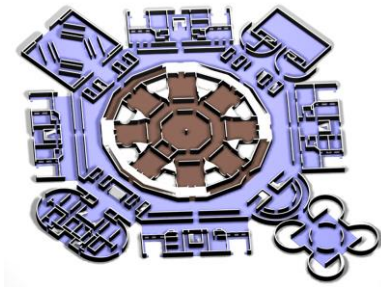

Ground level

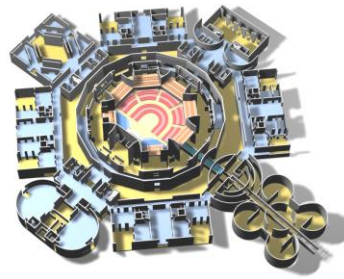

Second level of Assembly Building

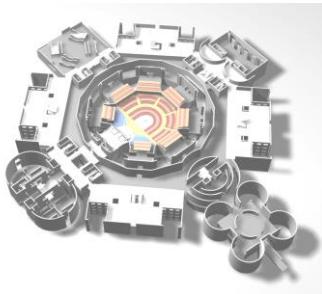

Third level of Assembly Building



Fifth level of Assembly Building

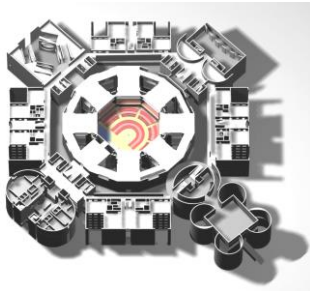

Sixth level of Assembly Building

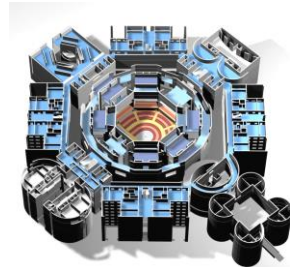

Eighth level of Assembly Building

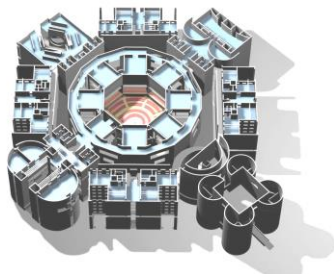

Ninth level of Assembly Building

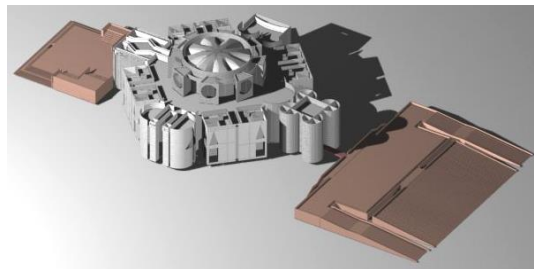

Full 3D model of the Assembly Building

Fig. 1. 3D models of different levels of National Assembly Building.

As the aim of the experiment was just not to make 3D models of same building with different techniques but also find their potentialities of architectural form and space analysis. So, different analytical diagrams for 'form analysis' (few of them are illustrated in Fig. 2-9) were developed with these three techniques. The illustrated diagrams have explored some possibilities of rendering with various combinations of surfaces with solids and wire-frame, varying intensity of shades and transparency with respect to light.

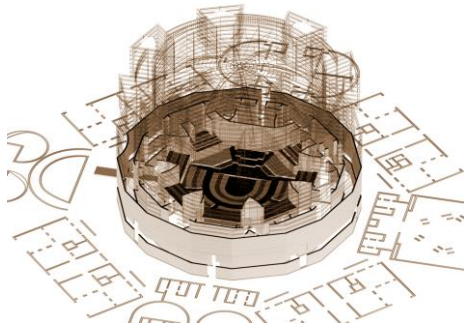

Fig. 2. 2D plan with transparent wire-mesh.

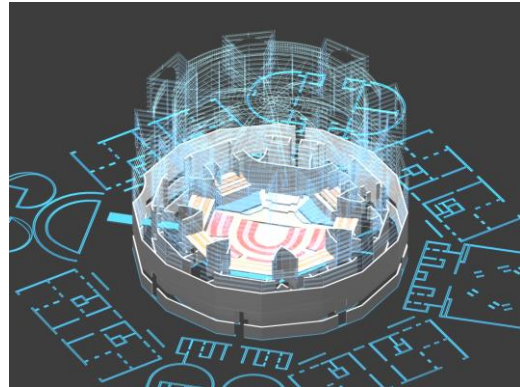

Fig.3. 2D, solid and wire-mesh with illumination



Fig. 4. Solid model with polygon and patch for roof

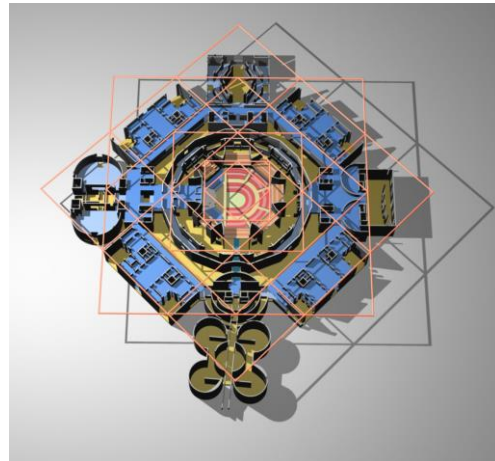

Fig. 5. Lines with polygonal 3d to understand the grid.  
(Source : Modified from Gast, 2001)

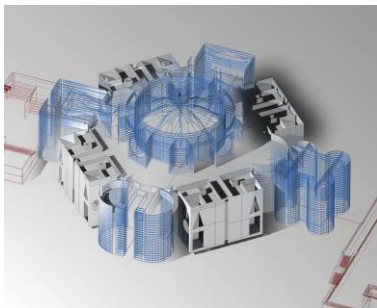

Fig. 6. Wire-mesh and solid : hybrid representation.

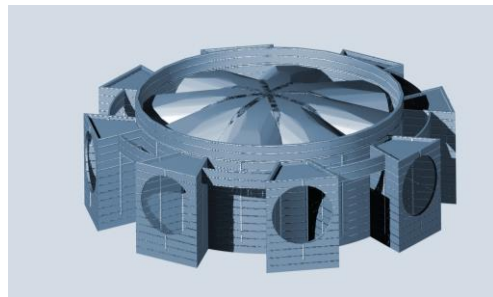

Fig. 7. Curves with patch techniques

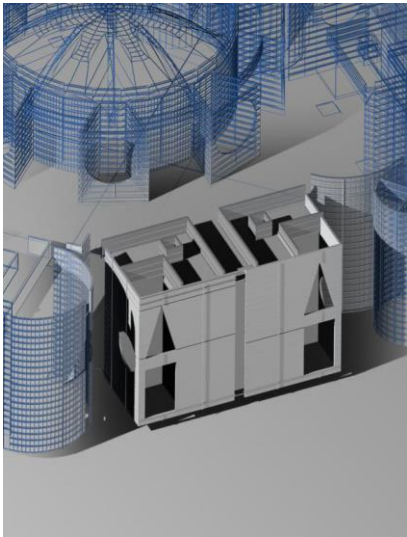

Fig. 8. Study of combinations of surfaces with solids and wire-frame, varying intensity of shades and transparency.

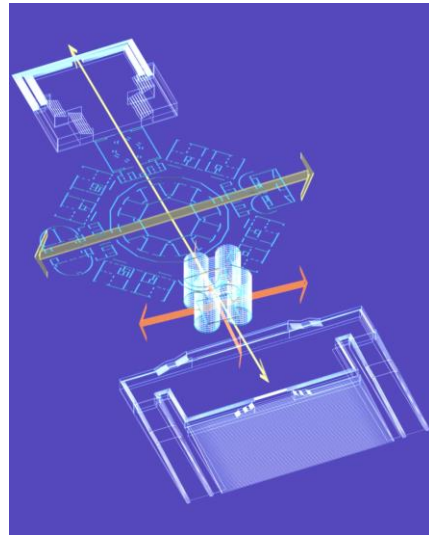

Fig. 9. Analytical model with varying intensity of shades and transparency.

While preparing the models, we found the following possibilities and constrains of the three techniques

**(a) Polygonal modeling:**

*Possibilities:* The study has found that Polygonal models works well with planar mapped surfaces such as: Flat ground planes, Floors and ceilings, Backdrops, Trees and bushes. It can be used to produce model of any object. It can create any surface with enough details also. This modeling technique is very much effective for architectural models if they are within right angles. Walls, windows, doors, and even interior furniture which are at right angles - works best with polygonal modeling.

*Constrains:* In making intricate details in a model with 'polygonal' technique, one requires more faces. As face count increases, computer's performance begins to degrade. It means that the designer needs to be careful at the time of building geometry and detailing. It is also difficult to edit detailed models due to their existing large number of faces. In Polygonal model making small changes can often be a significant challenge.

**(b) Patch modeling:**

*Possibilities:* Although the technology can build edges very easily, smooth surfaces are the best fit for Patch modeling. Creating organic shapes is very easy with this technique.

*Constrains:* Patch models have some limitations associated. It present problems if it is used to model in a predefined way. For instance, it is difficult to build an object like Loft object with defined shapes. However, it is possible to convert a Polygonal object to a Patch surface by applying the Edit Patch modifier in 3D Studio MAX<sup>®</sup>. Doing this turns Polygonal mesh into one big patch with a ton of vertices which slows down the machine. So, designer needs to be careful from the very beginning of modeling.

**(c) NURBS modeling:**

*Possibilities:* The study has found that almost any object can be build by using NURBS. The primary benefit of the NURBS method is that it has both modeling and editing flexibility. But one cannot rely on it for making complex meshes with detailed surfaces. In this respect, it is much easier to use Patch modeling. It is possible to build model, simply by using curves to define the surfaces. Those surfaces look rather low-detail in the view ports. However, those can present much higher level of complexity thus ensuring high detail model with low memory consumption. NURBS can give both smooth and contoured surfaces and keep mesh detail relatively low. It significantly increase performance versus the same model in polygonal form.

*Constrains:* NURBS models, for all intents and purposes, work in almost every situation. But the technique of NURBS modeling required skill and time. Aside from the complexity issue, it is also very difficult to *extrude* sections of a NURBS model at right angles. For the most part, NURBS models want to have curvature. It means that even if a model built with right angles, close inspection shows that it has some smoothness around the edges.

## Discussion

Reviewing works of analysis by various authors including Barker (a. Barker, 1989 & b. Barker, 1990), Clark and Pause (Clark, 1996), Ching, and Unwin (Ching, 1996), it can be said that all conventions of drawings (plan, section, elevation, axonometric, and perspective) need to be considered in order to represent analysis of form and space. Axonometric and aerial perspectives (with distant vanishing points) are also significantly effective because of their diagrammatic three-dimensional nature in communicating the main idea. Also highlighting parts or segments within the 3D diagram in an analytical illustration was another key techniques followed by the above authors. Fortunately, most of these unique improvised features are not commonly encountered in conventional computer presentation. These features include: wire-frame with varying line thickness, thicker profile lines, hidden line with varying thickness, dashed line in combination with hidden line, and dotted lines with arrows. Such features usually highlight and define an element, surface, volume or non-physical concept. In that respect, the study followed those techniques/features for making analytical diagram (Fig. 2 to 9). It may be interesting to compare the original concept of architect Louis I. Kahn about the assembly building. His sketch has been shown in Fig. 10.

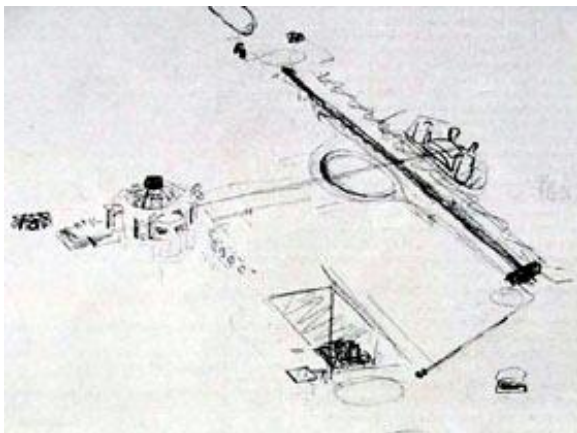

Fig.10. Early sketch of Kahn of Assembly building (Source : Heinz, 1987).

## Conclusion

The focus of all general purpose modeling application is to draw and render physical objects and render their material characteristics. In analysis, representation of non-physical objects (space, volume etc) is as important as the representation of physical objects (wall, floor etc). At present, the alternative solution for such a differentiation is the combination and variation of shades of color, transparency, and options of wire-frame variations, all within a rendering mode.

As mentioned, a 3D model in a computer environment is created with lines, rather than dots or broken lines. Some of the improvised and unique features shown in Fig.10, like a thicker profile line in a hand drawing do not represent a complete line or a specific number of lines that construct the model. A profile line includes only the peripheral segments, which a computer will not generate (SketchUp® claims they can, ref: <http://www.sketchup.com>). Although there are significant restrictions in representation of line drawings, we would expect computers to provide variations of shades, transparency, and luminance that are difficult to produce by hand and can become very effective for analytical models.

This short study has investigated only the features of popular 3D computer models with their possibilities and limitations to aid graphic analysis of built forms. Although there are specific limitations when it comes to wire-frame rendering, the strength of computational media has provided unlimited combinations of rendering modes (variation of surface shades, surface transparencies, illumination etc), options of motion capability, and choice of interactive features. It is true that a hand drawing can be improvised to highlight only part of a line or to thicken the periphery of a complex shape. A computer model cannot accomplish such tasks because of its pre-defined command structure. On the other hand, modeling, rendering and motion techniques in a computer environment can produce a new generation of hybrid images that can enhance the representation of analysis.

Learning is a never ending process. What we may need is to learn to perform more with less effort. The effectiveness of 3D computer models and their compatibility with various modes of representation make this medium significantly important in the context of architectural design, form and space analysis and teaching of design.

**Acknowledgement:** This study has been funded by Khulna University Research Cell.

## References

- Ching, F.D.K. 1996. *Architecture: Forms, Space, & Order*. Second edn., John Wiley & Sons Inc. pp.83-85.
- Clark, R.H. and Pause, M. 1996. *Precedents in Architecture*. Van Nostrand Reinhold, London, pp.07-22.
- Gast, K.P. 2001. *Louis I. Kahn : The idea of Order*. Birkhauser-Publishers for Architecture, Berlin, pp. 98-112.
- Barker, G.H. and Tucker, R.N. 1990. *The Interactive Learning Revolution: Multimedia in Education and Training*. Nichols Publishing, New York. pp. 86-87.
- Barker, G.H. 1989. *Design Strategies in Architecture – An approach to the analysis of form*, Second edition, Van Nostrand Reinhold (international). London. pp.30-62.
- Heinz, R.; Sharad, J. and Allesandro, V. 1987. *Louis I. Kahn: Complete Works 1935-1974*. Swiss Federal Institute of Technology, Zurich. pp. 75-76.
- Uddin, M.S. 2001. Extents and limitations of 3D computer models for graphic analysis of form and space in architecture. In: *eCAADe* (Education and research in Computer Aided Architectural Design in Europe). pp. 552-57.