



## A STUDY ON THE METHODS OF ESTIMATING THE STATE OF CHARGE (SOC) OF BATTERY

Abu Salman Khan\*, Tapas Kumar Singh, Md. Muhibul Islam

*Dept. of Electrical and Electronics Engineering, Shahjalal University of Science & Technology, Sylhet-3114, Bangladesh*

KUS: ICSTEM4IR-22/0034

Manuscript submitted: August 11, 2022

Accepted: September 27, 2022

### Abstract

Batteries are a popular and important item that are utilized as energy sources in a variety of applications. The rise of electric vehicles in the twenty-first century has increased its importance. A battery's state of charge (SoC) is critical information. It is vital to estimate SoC with a reasonable degree of precision. During charge and discharge cycles, lithium-ion batteries change their internal state. The level of charge of a lithium-ion battery changes throughout the charging cycle and is dependent on the internal structure of the components, which can degrade over time. Battery management systems that depend on charge counting and cell voltage monitoring frequently estimate the status of charge. It's difficult to tell what state the battery components are in physically. This work will focus on different methods of estimating SoC. Basically, this study will cover terminal Voltage method, Open Circuit Voltage Method, Coulomb Counting Method and a dynamic method based on Unscented Kalman Filter (EKF). The study will be based on simulation on MATLAB and it will also cover a practical experiment by charging and discharging a battery multiple time. A comparative study of the advantages and drawbacks of the existing methods will be discussed in this work.

**Keywords:** State of charge (SoC), Electric Vehicle, Battery management system, Kalman Filter (EKF), Coulomb Counting Method, MATLAB

### Introduction

Batteries are part of our everyday life. A day would not last without using mobile phones, tv remote or laptop. All of these appliances are run by batteries. The convenience of the batteries led to the invention of any more gadgets and gears. Rigorously battery is a series combination of several electrochemical cells. Sometimes a combination of batteries is referred to as a battery pack. The term State of Charge<sup>[1]</sup> indicates the amount of battery capacity remaining as a percentage of its rated value. We frequently need this information of battery when we various appliances run by rechargeable batteries. The mathematical model behind the determination of this valuable information carries a great impact on the determination process. A lot of researches have been

\*Corresponding author: <mukut.salman@gmail.com>

DOI: <https://doi.org/10.53808/KUS.2022.ICSTEM4IR.0034-se>

done to improve the techniques of estimating the state of charge of a battery. The more common techniques are Coulomb counting method (J. Du, Z. Liu, Y. Wang, C. Wen, 2014), terminal voltage method, Fuzzy logic method (C. Florin, R. Comeliu, N. Marian, G. Catalin, 2017), Kalman Filter method (H. Zhai, 2017), Extended Kalman Filter method (N. Shahab, 2016) etc. None of the techniques is hundred percent accurate. There are advantages and drawbacks of every method. This research is based on the previous works done on these methods and it will try to figure out the advantages and drawbacks of different methods. Battery modeling (Sepasi, Saeed. 2014) is one of the most important steps to develop any method to determine SoC. Battery modeling refers to making an equivalent circuit of a battery and setting the values of different parameters of the equivalent circuit. This study will use a simplified 1RC battery model for simulation.

Battery is a device used to generate electrical energy (Linden, David. Handbook of Batteries, 3rd ed., McGraw-Hill., New York, 2001). It converts chemical energy to electrical energy. Now-a-days there are numerous types of batteries e.g., Li-Ion battery, Ni-Cd battery, Lead Acid battery, Li-Po battery etc.

## **Materials and Method**

### ***Introduction to state of charge***

State of charge, abbreviated as SoC or SOC, is the most vital and most frequently used information of a storage cell. Whenever we use our laptop or mobile phone, we check the battery percentage every now and then. As the battery health or proper use of battery solely depends on its proper charging and discharging, we must have a reliable information about the available energy of the battery (Ng, Kong-Song, Huang, Yao-Feng, Moo, Chin-Sien, Hsieh, Yao-ching, 2009).

As previously mentioned, state of charge is the ratio of available energy to the rated capacity of a battery. Mathematically it can be written as,

$$\%SOC = \frac{\text{available Ah}}{\text{rated Ah capacity}} \times 100$$

We cannot measure the state of charge with perfect accuracy, rather we estimate it. So, the estimation method must be reliable and it should be less affected by errors. This dissertation will have a deep look on the most common methods of estimating state of charge.

### ***Methods of estimating state of charge***

The SoC can be estimated from the direct measured values such as terminal voltage, load current or impedance. The most common techniques to estimate SoC from direct measurement values are Open circuit voltage method and Impedance based method.

#### ***Open circuit voltage method***

Open circuit voltage is a straight forward method for estimating SoC. In this method OCV will be related to the SoC (Malkhandi, Souradip, 2006). This method uses the known discharge curve to estimate the SoC. However, the temperature and battery current have a big impact on the voltage. This approach can be improved by adjusting the voltage reading with a correction term proportionate to the battery current and employing a look-up table of the battery's open circuit voltage vs. temperature.

#### ***Impedance based method***

The composition of the active chemicals in the cell changes during the cell charge-discharge cycles as the chemicals are converted between the charged and discharged states, and this is reflected in changes in cell impedance. Thus, measurements of cell internal impedance may be used to compute SOC, but they are not

generally employed due to challenges in detecting the impedance while the cell is functioning, as well as issues in interpreting the data because the impedance is temperature dependent.

### ***Book keeping methods***

In this type of method, SoC estimation needs the previous history or initial state of the battery. The common book keeping methods are Direct Coulomb counting method and Modified Coulomb counting method.

### ***Coulomb counting method***

A charge's energy is expressed in Coulombs and is equal to the integral of the current's cumulative energy. By monitoring the current that enters (charges) or departs (discharges) the cells and integrating (accumulating) this over time, one may determine the remaining capacity in a cell. In other words, summing the current drain over time enables us to determine the charge that is moved into or out of the cell.

### ***Modified Coulomb counting method***

Modified Coulomb counting method solves the problem with Coulomb counting method partially. This method uses the redressed current value to estimate SoC with more accuracy. The revised current  $I_c$  is a function of discharge current  $I_d$ .  $I_c$  is a quadratic function of  $I_d$  (Kang L, Zhao X, Ma J. 2014).

### ***Adaptive methods***

Adaptive methods are recursive, self-learning methods. For example, Kalman Filter method, Unscented Kalman Filter method, Extended Kalman Filter Method, Fuzzy logic method, BP Neural network methods etc.

### ***Kalman filter, extended Kalman filter and unscented Kalman filter methods***

In order to anticipate values, a Kalman filter is a useful tool. Rudolf Kalman created it for the first time in the 1960s. A series of equations and successive data inputs are used in an iterative mathematical procedure to estimate the values. Kalman filters works with gaussians or normal distribution. It can only be implemented in linear systems. Kalman Filter can be implemented to estimate SoC considering the SoC as a linear function of OCV.

In reality, SoC is not linear with the OCV. Therefore, Extended Kalman Filter (EKF) is used which works in non-linear systems. Unscented Kalman Filter (UKF) is also used in non-linear system. The main advantage of this method is its performance.

### ***A brief overview on Kalman filter***

Kalman Filter (Rudolf E. Kalman, 1960) works on linear system driven by stochastic process. It basically consists of two steps viz. predict and update. At first a prediction is done depending on the initial value of the system. Then prediction is done about the variance according to the white noise of the system.

In update step, following consideration of the measured value, the difference between the predicted value and the measured value is computed. The value to be retained is then determined using Kalman gain. The new value and new variance are then determined based on the Kalman gain's estimate. The output of the update step is again given to the predict state and this iterative method is continued until the variance converges to zero.

The Kalman Filter equations are as follows-

$$\begin{aligned}x_k &= Ax_{k-1} + Bu_k + w_{k-1} \\z_k &= Hx_k + v_k\end{aligned}$$

Here  $x_k$  is the present state and  $x_{k-1}$  is the previous state of the system.  $U_k$  is the control signal and  $w_{k-1}$  is the process noise which is in maximum time a white noise or Gaussian noise. In the second equation,  $z_k$  is the measurement value which is a linear combination of current state and the measurement noise,  $v_k$ . A, B and H are three matrices which may contain operator or constant value

$$\text{Kalman Gain, } K_k = \frac{P_{k-}}{P_{k-} + R}$$

Table 1. Steps and equation for Kalman Filter

Predict	Update
$\hat{x}_{k-} = A\hat{x}_{k-1} + Bu_k$	$\hat{x}_k = \hat{x}_{k-} + K_k(z_k - H\hat{x}_{k-})$
$P_{k-} = AP_{k-1}A^T + Q$	$P_k = (1 - K_kH)P_{k-}$

$$K_k = P_{k-}H^T(H P_{k-}H^T + R)^{-1}$$

Above those equations are elaborately described in Introduction to Random Signals and Applied Kalman Filtering named paper.

#### **Extended Kalman filter**

Extended Kalman Filter or EKF is simply the nonlinear version of Kalman Filter. It is used in nonlinear systems. As most of the systems in the universe are nonlinear, EKF is more useful than Kalman Filter.

The equations used in EKF are (Rudolf E. Kalman, 1959 and 1961)

$$\begin{aligned} x_k &= f(x_{k-1}, u_k) + w_k \\ z_k &= h(x_k) + v_k \end{aligned}$$

Here  $w_k$  and  $v_k$  are the process noise and observation noise with covariance  $Q_k$  and  $R_k$  and  $u_k$  is the controlling signal.

#### **The unscented Kalman filter**

In case of wide nonlinearity of the system, EKF prediction is very poor. So, an improved method called Unscented Kalman Filter (UKF) is used. In contrast with EKF, UKF uses a bunch of points called sigma points instead of one point (E. A. Wan and R. van der Merwe, 2000). The steps of UKF are given below.

##### *Predict*

- Generate sigma points
- Predict sigma points
- iii) Predict mean and covariance

##### *Update*

- Predict measurement
- Update state

### **Fuzzy Logic method**

There are two definitions of fuzzy logic. Fuzzy logic may be thought of as a limited form of multivalued logic's logical framework. The theory of fuzzy sets, which deals with classes of objects with ambiguous borders and membership that depends on degree, is nearly a synonym for fuzzy logic (FL) in a broader sense. Fuzzy logic allows complicated systems to be described using a greater degree of abstraction resulting from human knowledge and experience, in contrast to classical logic which necessitates a profound grasp of a system, accurate equations, and precise numeric values. It enables the subjective expression of this information through terms like huge, little, extremely hot, blazing red, a long time, rapid, or slow (Arabacioglu, B. C. 2010)

### **Neural network**

An information processing, memory, and learning architecture known as a "neural network" are based on the interconnected system of neurons in the human brain. It imitates the brain's capability for pattern recognition and learning through errors, identifying and extracting the relationships with the data. (Marvin Minsky and Seymour Papert, 1969)

### **State of charge estimation**

In this chapter the works on estimating SoC are presented. MATLAB R2015b and MATLAB R2018a were used for simulation. The blocks were designed in SIMULINK. This chapter will include works on terminal voltage method, Coulomb Counting Method and Unscented Kalman Filter method.

### **Impedance based method or terminal voltage method**

For this experiment, lithium-ion battery with 1RC model and Lead acid battery will be used. In this simulation, the plot of open circuit voltage vs time, SoC vs time and load current vs time curve will be shown.

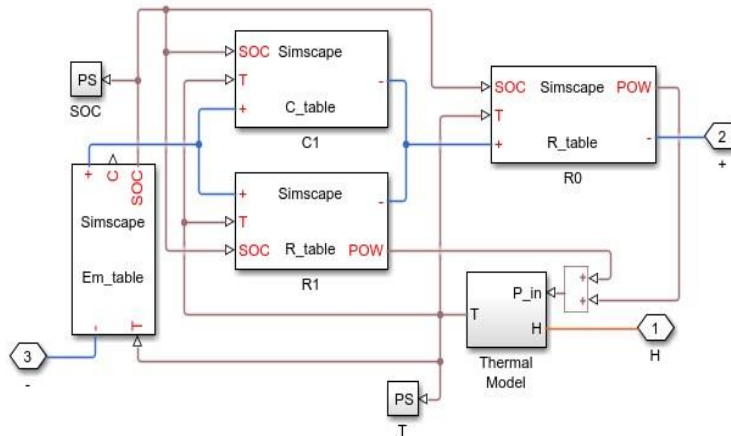

Figure 1. 1RC model of Lithium-ion battery.

*Em\_table*: this block includes the open circuit emf table of the battery and it works as a voltage source

*R\_1*: This block corresponds to the effect of polarization resistance.

*C\_1*: Corresponds to the polarization capacitance.

*R\_0*: Corresponds to the resistance of electrolytic material and terminal resistance

*Thermal model*: Corresponds to the temperature effect.

The full model is shown in Figure 2.

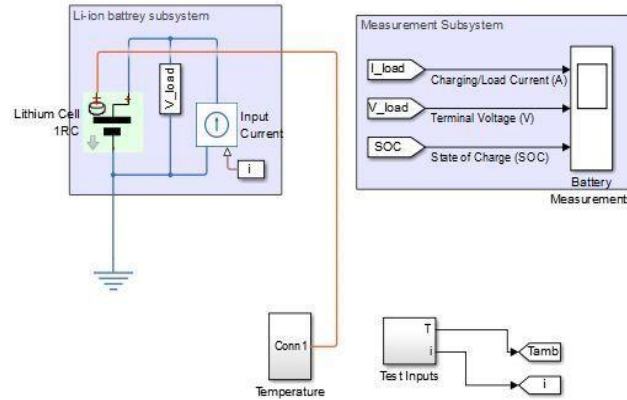

Figure 2. Simulink design to perform  $V_t$  vs SOC experiment.

Lithium cell 1RC: This block contains a lithium-ion battery of 3 cells with the model shown in Figure 2.

The following figures show the lithium-ion battery data. The three columns correspond to 3 lithium-ion cells.

Variables - Capacity_LUT				
C1_LUT	R1_LUT	R0_LUT	Capacity_LUT	
1x3 double				
	1	2	3	5
1	28.0081	27.6250	27.6392	
2				
3				

Variables - C1_LUT			
C1_LUT	R1_LUT	R0_LUT	
7x3 double			
	1	2	3
1	1.9136e+03	12447	30609
2	4.6257e+03	18872	32995
3	23306	40764	47535
4	10736	18721	26325
5	18036	33630	48274
6	12251	18360	26839
7	9.0229e+03	23394	30606
8			
9			

Variables - R0_LUT			
C1_LUT	R1_LUT	R0_LUT	
7x3 double			
	1	2	3
1	0.0117	0.0085	0.0090
2	0.0110	0.0085	0.0090
3	0.0114	0.0087	0.0092
4	0.0107	0.0082	0.0088
5	0.0107	0.0083	0.0091
6	0.0113	0.0085	0.0089
7	0.0116	0.0085	0.0089
8			

Variables - R1_LUT			
C1_LUT	R1_LUT	R0_LUT	
7x3 double			
	1	2	3
1	0.0109	0.0029	0.0013
2	0.0069	0.0024	0.0012
3	0.0047	0.0026	0.0013
4	0.0034	0.0016	1.0000e-03
5	0.0033	0.0023	0.0014
6	0.0033	0.0018	0.0011
7	0.0028	0.0017	0.0011
8			

Figure 3. Data table of cell capacity (Ah),  $R_0$ (ohm),  $R_1$ (ohm) and  $C_1$ (F).

Measurement subsystem: this scope plots the SoC, terminal voltage and charging currents. Test input: this block includes a current signal and a temperature signal generator which is fed to the lithium-ion cell.

**Graphical results:**

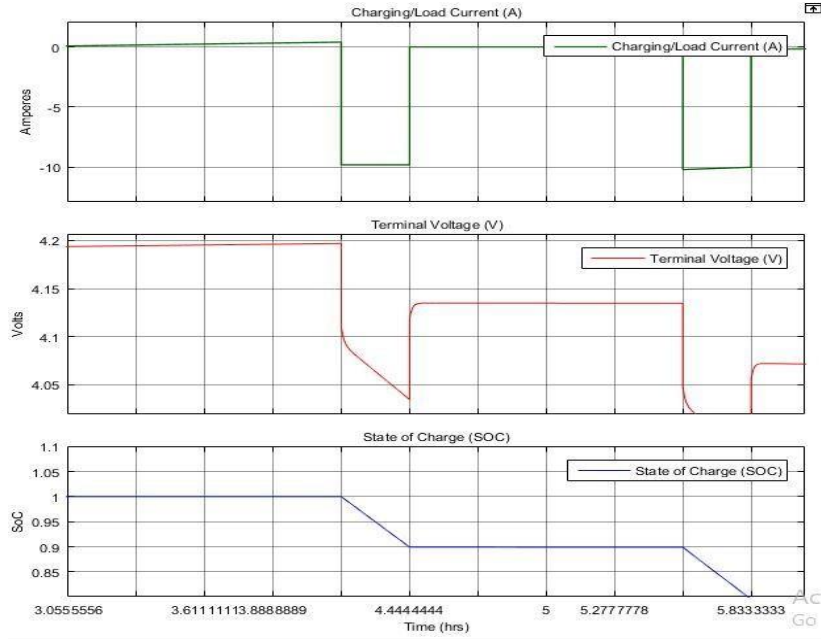

Figure 4. Zoomed in version of figure in Simulink.

From the above shown graphs, it can be seen that the charging/discharging current, terminal voltage and SoC of the battery. The simulation was run for 12 hours.

The first current pulse of 10A charges up the battery. While the battery is being charged, the SoC gradually increases from 40% to 100%. At the same time the terminal voltage of the battery rises from 3.7Volts to 4.3Volts. The charging period continues for 2hrs.

The battery is then kept in rest. During rest, the SoC remains constant at 100% and the terminal voltage falls to 4.2Volts. This is the open circuit voltage of the battery.

In the next stage, negative current pulse is applied with regular resting period. The negative current pulse indicates the discharging of the battery. In discharging periods, the battery terminal voltage falls almost linearly with the SoC. This change in terminal voltage and SoC is clearly shown in the zoomed version.

The following figures show the current, terminal voltage and SoC plot of a Lead acid battery. So, from the above discussion, the conclusion can be drawn that, terminal voltage can be used to estimate SoC. A mathematical model can be made where the SoC will be a function of terminal voltage.

Since the linearity is almost maintained, the model can be simplified considering the linearity of terminal voltage with SoC. Terminal voltage can be expressed as a function of time during discharge period.

$$V_t = k_0 t + k$$

Here  $k_0$  and  $k$  are two constants that can be evaluated from the practical experimental data. SoC can be expressed as

$$SOC = \frac{V_t - K^2}{K_1}$$

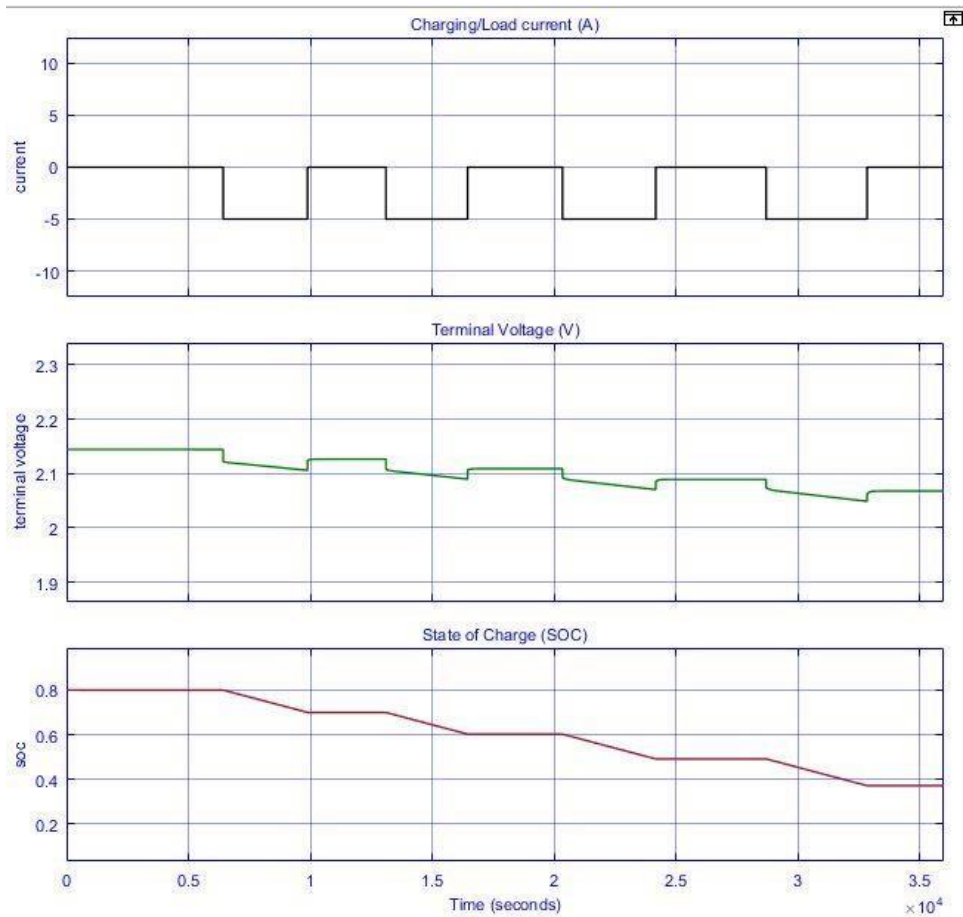

Figure 5. Discharging of a lead acid battery.

Advantages of this method are:

- Easy to implement
- Less costly
- Simple mathematical model

Drawbacks with this method are:

- Very rough approximation
- Cannot estimate efficiently in the exponential region

Due to the lack accuracy, this model cannot be implemented in the fields where high accuracy of SoC estimation is desired.

### ***Open circuit voltage method***

As mentioned earlier, the open circuit voltage of a battery is a function of SoC, it can be used to estimate the state of charge. The following graph shows the relationship between OCV and SoC.

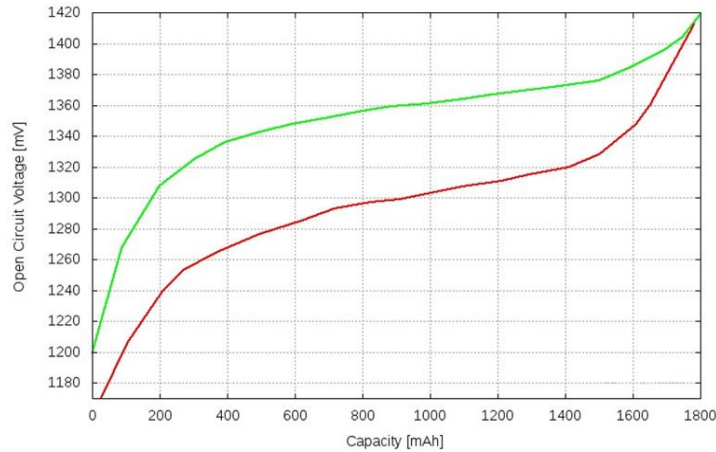

Figure 6. OCV vs SoC curve of Ni-MH(Charging/Discharging).

The green curve indicates the charging phase and the red curve indicates the discharging phase. There is a hysteresis effect in the full cycle i.e., the path followed in charging phase is not same in the discharging phase. One of the reasons for the hysteresis in Charge discharge plot is poor kinetics. Such a poor kinetics is again related to diffusion of ions.

### ***Open circuit voltage method with simulation***

In MATLAB Simulink R2015b, the simulation of discharging lithium-ion battery was done. From the graphs of Figure 7, it is clear that the OCV gradually falls with the discharging and rises with the charging. The whole curve is non-linear, but it has a very large linear region which can be used to estimate SoC.

The SoC can be expressed as a function of OCV.

$$\text{SOC (\%)} = f(\text{OCV})$$

Advantages of this method

- Very straightforward method
- Easy to implement and less costly

Drawbacks with this method

- This method only works at open circuit condition
- Cannot estimate at exponential region properly

The linearity consideration leads to significant error.

### ***Coulomb Counting method***

The main approach of coulomb counting method is quite straight-forward. Here, the charging or discharging

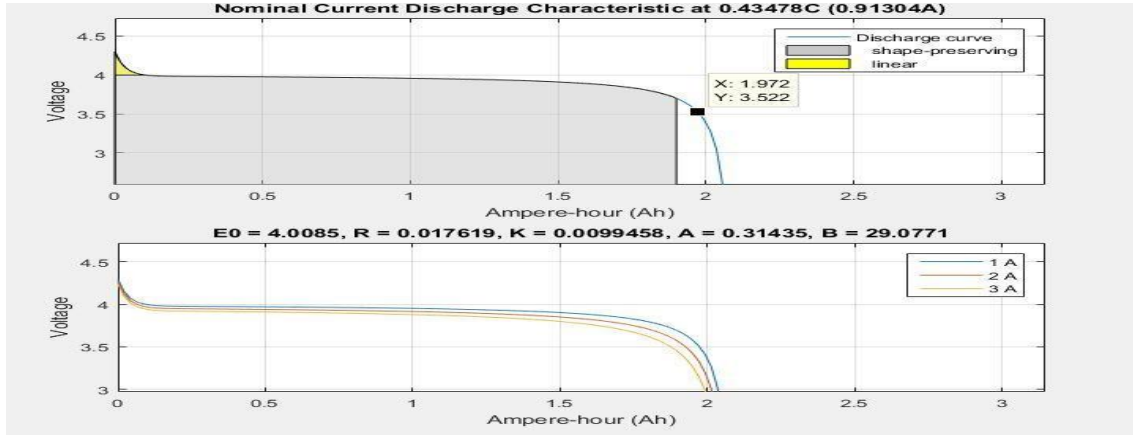

Figure 7. Discharging of a lithium ion battery at different currents.

current of a battery is integrated over time to estimate the SoC in this method, the initial SoC has to be known prior.

The Ah capacity of a battery is the measurement of charge stored in it. Again, the current integrated over time gives us the amount of charge flown. So, the SoC can be estimated by subtracting the percentage of charge flown through the load from initial SoC in discharging phase. Again, in charging phase, the SoC can be estimated by adding the percentage of charge with respect to the rated capacity that is stored to the initial SoC. So, the mathematical equation can be written as,

For charging-

$$SoC(t) = SoC(0) - \frac{\eta}{Q} \int_0^t Idt$$

Here, SoC(0) is the initial SoC, SoC(t) is the estimated SoC at time t, Q is the rated capacity in As (=3600xAh), I is the discharge current and  $\eta$  is the Coulombic efficiency. In this work Coulombic efficiency is taken 1 for simplicity as its real value is very close to 1.

To simulate the Coulomb counting method, the mathematical model is designed in SIMULINK. MATLAB R2015b was used to design the model. The model is shown below.

In this model Lead Acid battery was used at source and a dc machine as discharging load. The subsystem to estimate SoC consist of an integrator, a subtractor, a divider and two constants. A scope was used to plot the estimate load current, terminal voltage and estimated SoC. Because the Powergui block opens a graphical user interface (GUI) that shows steady-state values of observed current and voltages as well as all state variables, it was decided to add the Powergui (Power Graphical User Interface) block. We may change the beginning states using the Powergui block so that the simulation can begin under any initial circumstances. The constant 100 is the initial SoC and the constant 0.36 corresponds to the rated capacity. The simulation was run for 6 seconds. The simulated results are shown in the following graphs.

The graph shows the SoC as well as voltage of the battery as a discharging current of 1.2A is drawn by the machine. At the beginning the machine draws a very large amount of current and voltage falls rapidly. At steady state condition the machine draws a constant current and the SoC and the voltage falls almost linearly.

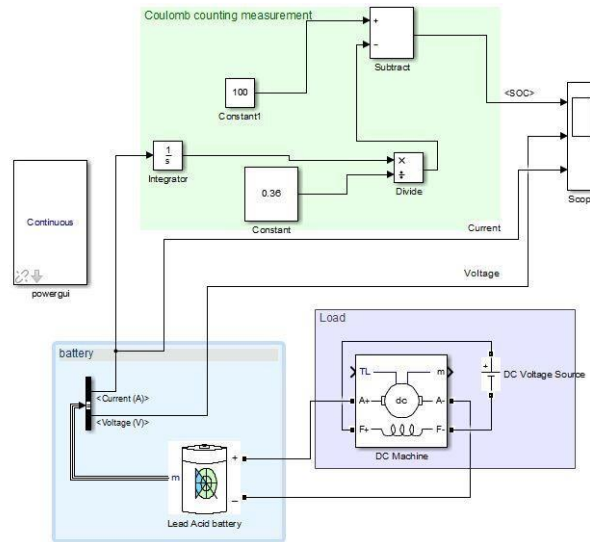

Figure 8. SIMULINK Model for Coulomb Counting method.

Battery specification is given as a table.

Table 2. Battery specification of coulomb counting method simulation

Battery type	Lead-Acid battery
Nominal Voltage	250V
Rated Capacity	0.01Ah
Internal resistance	0.00003ohm
Exponential zone voltage	252V
Fully charged voltage	260V

Advantages of this method

- As this is book keeping method, it works dynamically.
- It works perfectly at the exponential region.
- The implantation is easy.
- Simple mathematical model

Drawbacks with this method

- The initial SoC must be known.
- It cannot be used at open circuit condition
- Affected by the aging effect as capacity degrades with time.

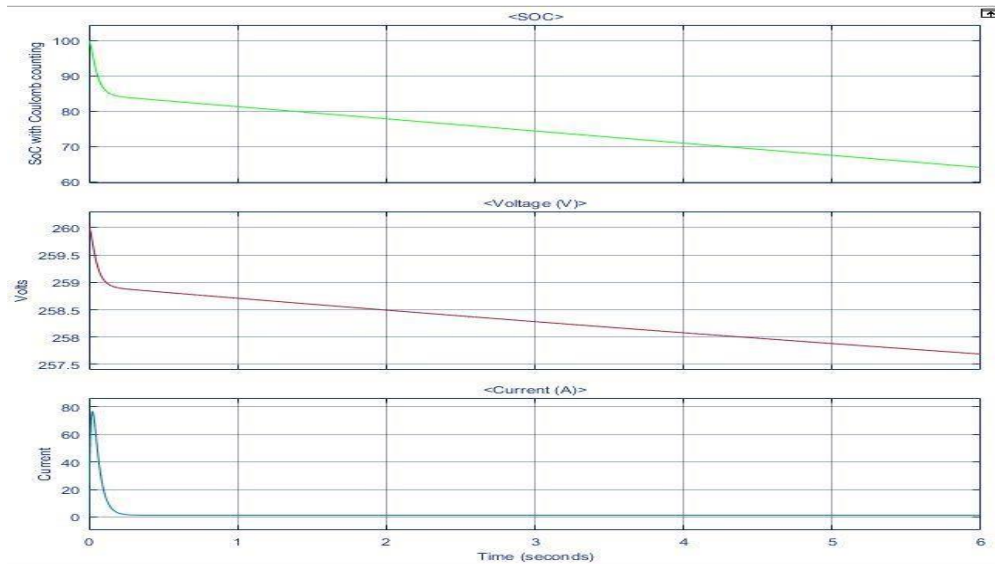

Figure 9. SoC,  $V_t$  and Current vs time plot.

### ***The unscented Kalman filter method***

In this model a Lithium-ion battery with 1RC equivalent circuit model is used. The model is shown below. The model consists of a voltage source  $E_m$ , a series resistor  $R_0$  and a single RC block with components  $R_1$  and  $C_1$ . In this simulation battery will go through several charging and discharging cycle. Battery capacity degrades with the charging discharging cycle. This degradation results in an error in SoC estimation. UKF algorithm is used to estimate the SoC of the battery.

In MATLAB Simulink a function operator The MATLAB Simulink model to simulate Unscented Kalman Filter (UKF) is used shown below. This model includes a subsystem of li-ion battery, a subsystem of event based Kalman Filter, a UKF block.

Where  $E_m$  (SOC,  $T_b$ ) is the electromotive force from the voltage source,  $E_m$  (SOC,  $T_b$ ) is the measured output voltage,  $R_0$  (SOC,  $T_b$ ) is the serial resistor, and  $V$  and are the measurement noise.  $R_0$ ,  $R_1$ ,  $C_1$ , and are 2D look-up tables in the model that change on SOC and battery temperature. The parameters in the look-up tables are identified using experimental data. To use the UKF block, the measurement and state transition functions were specified using Simulink functions.

The current signal is randomly given to the battery. At first the battery was randomly discharge and then recharged in constant current. The simulation was run for 20000 seconds. In this interval of time, battery discharge-charge cycle repeats for several times. From the above figures it is seen that the UKF estimation of SoC is very close to the real SoC.

Advantages of this method

- This method is an online estimation method
  - Very high accuracy can be obtained
- Works with fair accuracy at very random discharge rate

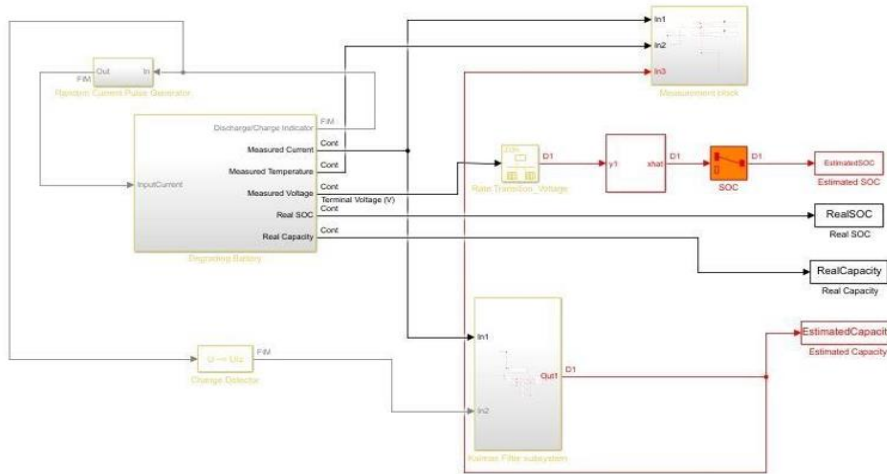

Figure 10. SIMULINK model for UKF method.

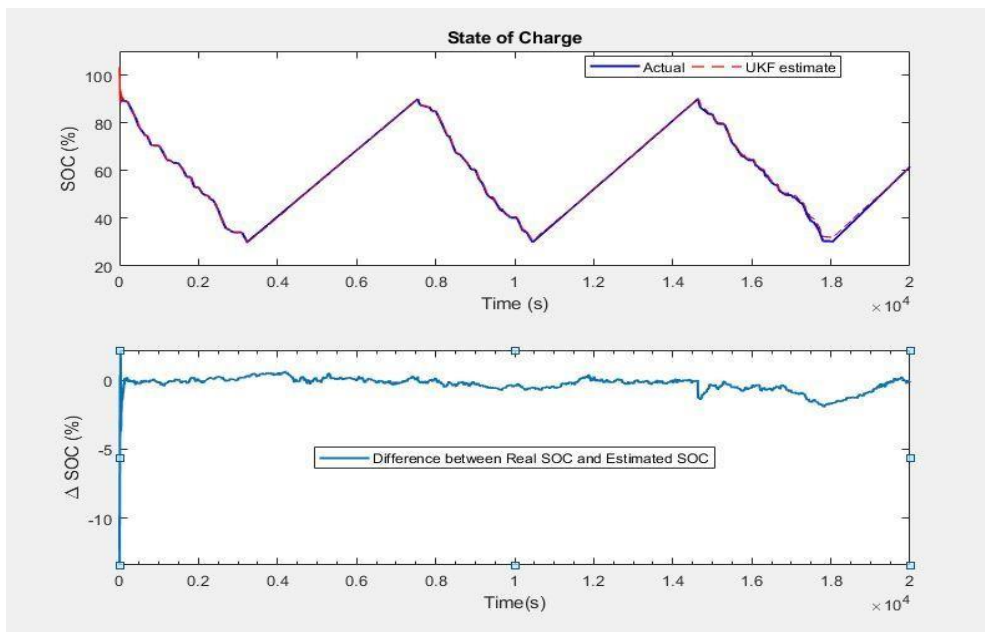

Figure 11. Real and estimate SoC vs time and ΔSoC vs time plot.

**Drawbacks**

- Complex mathematical modelling
- Costly to implement

### ***Comparative discussion on the methods***

A conclusion can be drawn from the above studies. The work can be summarized in a comparative discussion and it is given below.

#### *a) Terminal voltage method vs open circuit voltage method*

- Terminal voltage method can be used at loaded condition where OCV method is only used at unloaded condition.
- Both the methods work at almost same degree of accuracy iii) Terminal voltage method consumes less time than OCV method as circuit connection doesn't need to be interrupted

So it can be concluded that terminal voltage method is apparently better than OCV method.

#### *b) Terminal voltage method vs Coulomb counting method*

- Terminal Voltage method is simpler than coulomb counting method
- As Coulomb counting method is a book-keeping method, it gives better accuracy than terminal voltage method

So coulomb counting method can be implemented where more accuracy is desired.

#### *c) Coulomb counting method vs UKF method*

- UKF method gives more precise and accurate estimation than Coulomb counting method
- UKF method implementation is more complex and costlier than Coulomb counting method

So, a trade-off between accuracy and cost is required. Where excellent accuracy is desired UKF method can be implemented.

### **Conclusion**

The world is heading towards the green energy sources like solar energy. Automobiles are now-a-days designed with hybrid system. Hybrid Electric Vehicles (HEV), Electric Vehicles (EV) and smart grid are getting attention. These systems require rechargeable battery. Consequently, the demand of the rechargeable batteries is increasing. To operate a battery properly and to ensure longer battery life, it is very necessary to charge/discharge a battery when required. This leads to the requirement of designing an efficient Battery Management System (BMS) which will estimate SoC with an appreciable accuracy.

This work was intended to cover all types of methods of SoC estimation except hybrid methods. The authors worked to make a comparison among the existing methods, which can facilitate the implementation of SoC estimation scheme.

As this work did not take the aging effect and the SOH effect of large battery packs into account, there is a scope of doing further study based on this work.

### **Acknowledgement**

We are very thankful to all our honorable teachers of the department of electrical and electronic engineering, SUST for inspirational appreciation, direction of our research and suggestions. We would like to acknowledge the help our beloved friends in this work.

### **Conflict of interests**

The authors have declared no conflict of interests.

### Author Contribution

Abu Salman Khan: Writing – review & editing, Writing – original draft, Materials and Methodology, Investigation, Analysis and Interpretation of results, Supervision. Tapas Kumar Singh: Writing – review & editing, Methodology, Checking Error, Conceptualization, Md. Muhibul Islam: Writing – review & editing, Writing – draft manuscript preparation, Materials and Methodology, Investigation, Checking Error. All authors reviewed the results and approved the final version of the manuscript.

### References

- Ng, Kong-Song, Huang, Yao-Feng, Moo, Chin-Sien, Hsieh, Yao-ching, (2009) An enhanced coulomb counting method for estimating state-of-charge and state-of-health of lead-acid batteries. <https://doi.org/10.1109/INTLEC.2009.5351796>
- J. Du, Z. Liu, Y. Wang, C. Wen, (2014) A fuzzy logic-based model for li-ion battery with SoC and temperature effect. <https://doi.org/10.1109/ICCA.2014.6871117>
- P. Spagnol, S. Rossi, S.M. Savaresi, (2011) Kalman Filter SoC Estimation for li-ion batteries. <https://doi.org/10.1109/CCA.2011.6044480>
- C. Florin, R. Comeliu, N. Marian, G. Catalin, (2017) Extended KAlman Filter for State of charge estimation in electric vehicle battery packs. <https://doi.org/10.1109/OPTIM.2017.7975036>
- H. Zhai, (2017) Modeling of Lithium-ion Battery for Charging/Discharging Characteristics Based on Circuit Model. <https://doi.org/10.3991/ijoe.v13i06.6799>
- N. Shahab, (2016) Adaptive Techniques for Estimation and Online Monitoring of Battery Energy Storage Devices.
- Sepasi, Saeed. (2014) Adaptive State of Charge estimation for battery packs. <https://doi.org/10.13140/RG.2.1.4737.5209>
- Linden, David. Handbook of Batteries, 3rd ed., McGraw-Hill, New York, 2001.
- Piller S., Perrin M., Jossen, (2001) A methods of State of Charge determination and their application. [https://doi.org/10.1016/S0378-7753\(01\)00560-2](https://doi.org/10.1016/S0378-7753(01)00560-2)
- M.A.U.S NAvaratne, R.V. Koswatta, S.G. Abeyratne, (2009) A simple battery chemistry identification and implementation technique for a self-adaptable charger. <https://doi.org/10.1109/ICIINFS.2009.5429872>
- M. Urbain, S.Rael, B.Davat, P.Desprez, (2007) State Estimation of a Lithium-Ion Battery Through Kalman Filter. <https://doi.org/10.1109/PESC.2007.4342463>
- Ng, Kong-Song, Huang, Yao-Feng, Moo, Chin-Sien, Hsieh, Yao-ching, (2009) State-ofcharge estimation with open-circuit voltage for lead-acid batteries. <https://doi.org/10.1109/PECON.2008.4762614>
- S. Sindhuja, K.Vasanth, (2015) Modified coulomb counting method of SoC estimation for uninterruptible power supply system's battery management system. <https://doi.org/10.1109/ICCICCT.2015.7475275>
- R.G. Brown, Patrick Y.C. Hwang, (2012) Introduction to Random Signals and Applied Kalman Filtering. Malkhandi, Souradip, (2006) Fuzzy logic-based learning system and estimation of state-of charge of lead-acid battery. <https://doi.org/10.1016/j.engappai.2005.12.005>
- Kang L, Zhao X, Ma J. (2014) A new neural network model for the state-of-charge estimation in the battery degradation process. *Appl. Energy* 2014; 121:20–7. <https://doi.org/10.1016/j.apenergy.2014.01.066>